

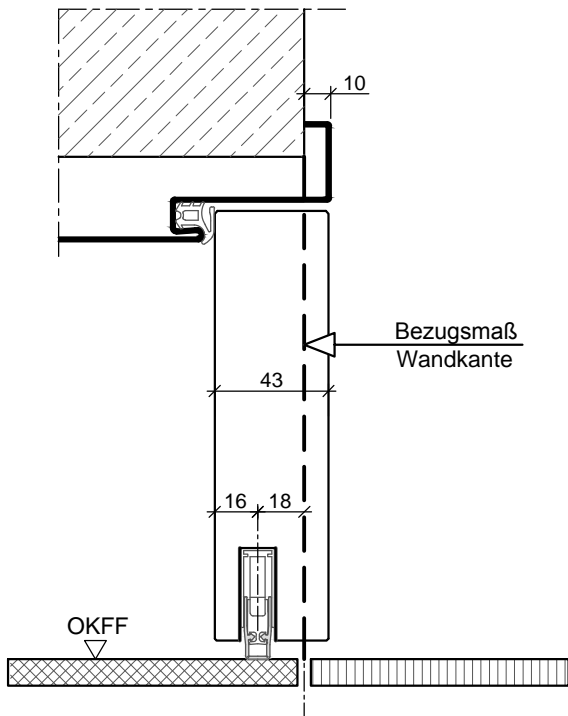

2. Technik / Grundlagen	2
2.5.2 Türstärke 43 mm	2

Türstärke 43 mm



HW43-stumpf in Stahlzarge

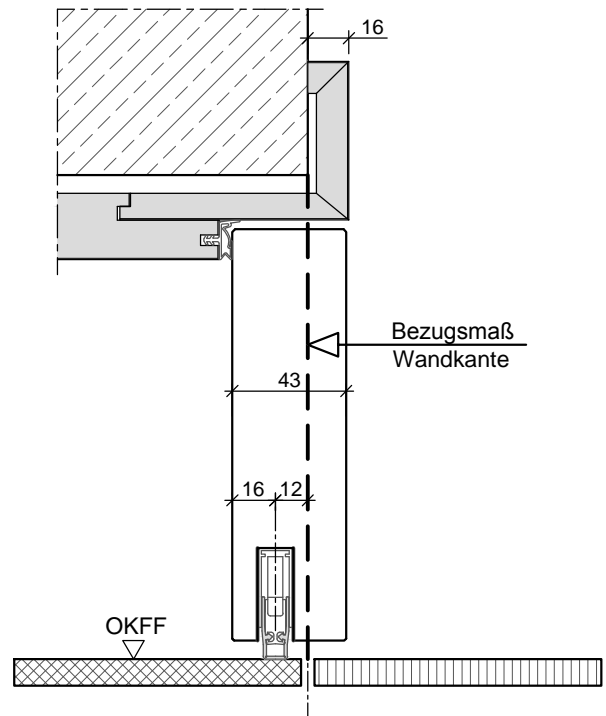

HW43-stumpf in Holzumfassungszarge

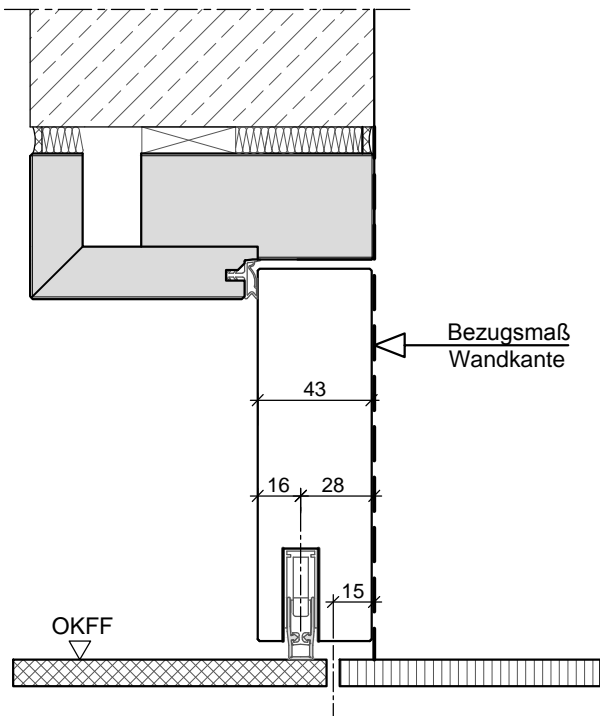

HW43-stumpf in Holzblockzarge

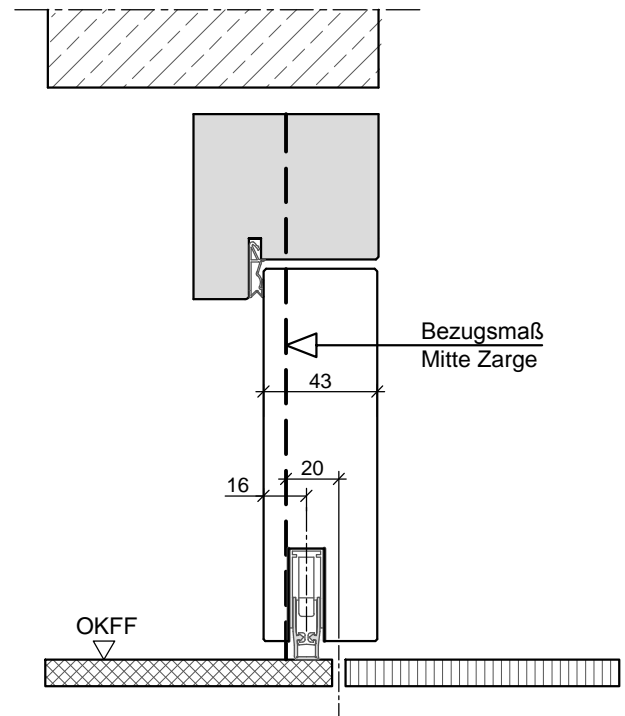

HW43-stumpf in Stockzarge

Türstärke 43 mm

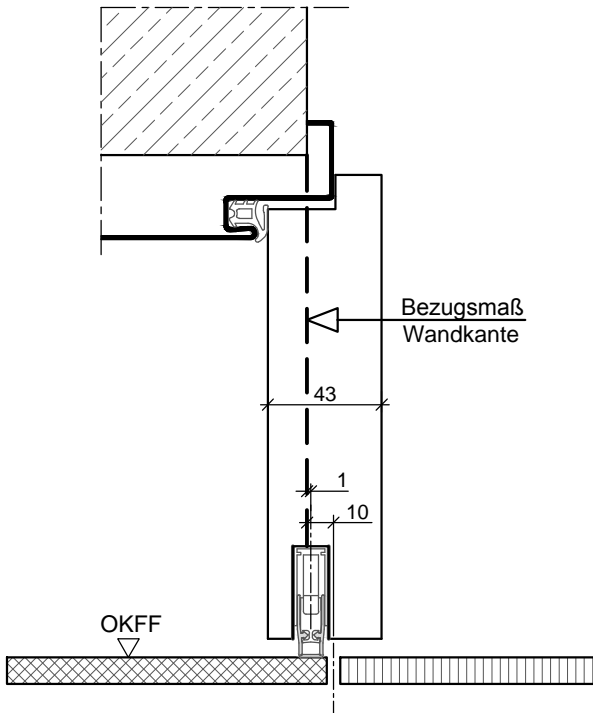

HW43-gefälzt Stahlzarge

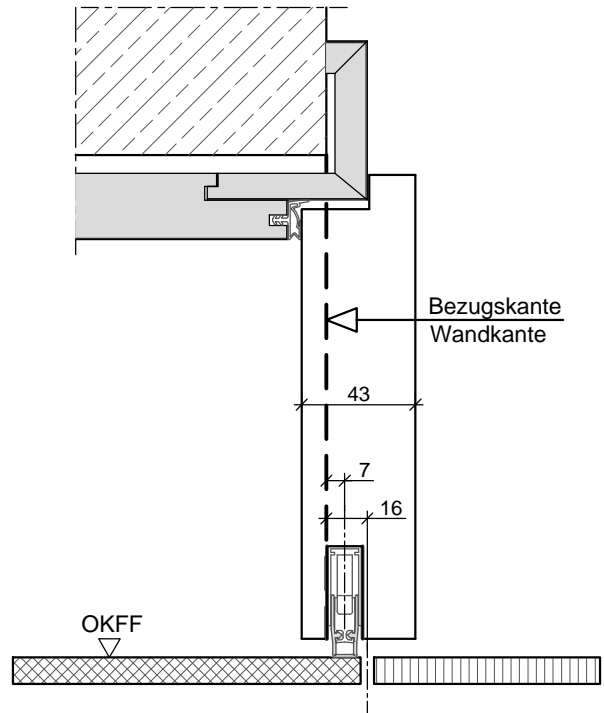

HW43-gefälzt in Holzumfassungszarge

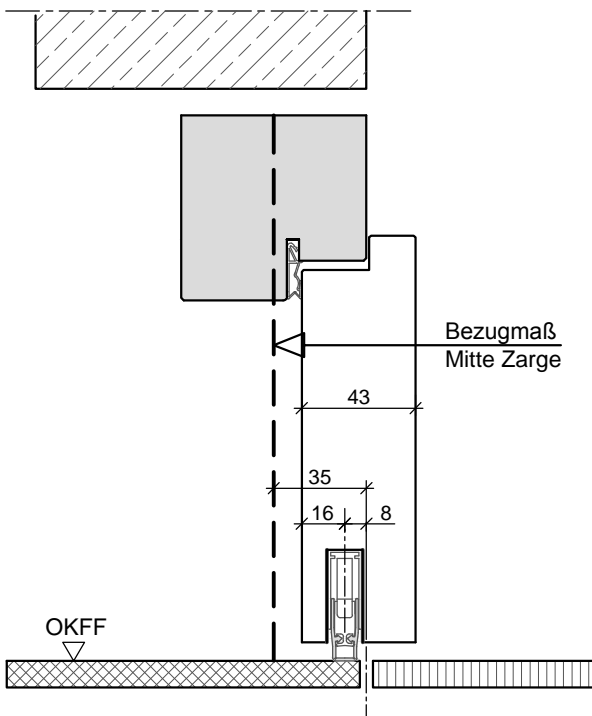

HW43-gefälzt in Stockzarge